

General

This overload devices are designed to prevent the loads getting harm from high currents and ability of control at the same time.

Usage of Device and Working Principle

Please make the connection according to the diagram. Otherwise device energise the device. When the device is energised it shows "High current set value" on top display, "Number of using contacts" (on and off) on mid display and "Hours worked" (when the relay is switched on) on bottom display.

Setting High Current Value: When the devices is energised you can make adjustment of overload by "A>" knob. While you are making your adjustment with this button set value can be seen on the left side display.

Setting Error Delay Time: Delay time is able to be adjusted by "t" knob. When the adjusting is being done the values can be seen on the left side display.

Normal Operation (No Error): When the device is energised, the device runs the motor and output **OUT** led gets on. Also, the **NO** contacts of the device are short-circuited and the **NC** contacts are open-circuited. **ERR NO** contacts are open-circuited and **ERR NC** contacts are short-circuited.

High Current Error: If the existed current is higher than adjusted, it counts as long as its delay time and the device stops the motor, **Err** led gets on, **OUT** led gets off. The display group of the phase entering the high current fault flashes. Also, the **NO** contacts of the device are open-circuited and the **NC** contacts are short-circuited. **ERR NO** contacts are short-circuited and **ERR NC** contacts are open-circuited.

Demurrage (Start Current): After the relay is energized or reset, the device does not current control for 5 seconds. Allows to demurrage.

Asymmetry: If there is more than 50% difference between the highest and lowest current passing on the phases, the device will enter asymmetry fault within 2 seconds. When the device enters the asymmetry error, the display group of the two phases causing the fault flashes and error LED is on. If the current is less than these values, the device does not control asymmetry. **5A for KON-TER-50.**

The device has to be manually reset in order to exit from the asymmetry error.

Reset: The **RESET** button must be pressed to reset when the device is in high current failure. After resetting the device, Err led it will turn off and the Out led will be on. the device runs the motor and output **OUT** led gets on. Also, the **NO** contacts of the device are short-circuited and the **NC** contacts are open. **ERR NO** contacts are open and **ERR NC** contacts are short-circuited.

Auxiliary Contacts:

NO Auxiliary Contacts (13-14 & 43-44) Short-circuited during normal operation (no error), open circuit when there is an high current and asymmetry error.

NC Auxiliary Contacts (21-22 & 31-32) Open circuit during normal operation (no error), short circuit when high current and asymmetry error.

NOTE: If there is no power on the device, Normally Open (**NO**) Auxiliary Contacts are open and Normally Closed (**NC**) Auxiliary Contacts are short-circuit.

Error Contacts:

NO Error Contact (97-98) Open circuit during normal operation (no error), short circuit when high current and asymmetry error.

NC Error Contact (95-96) Short-circuited during normal operation (no error), open circuit when there is an high current and asymmetry error.

NOTE: If there is no power on the device, Normally Open (**Err NO**) Auxiliary Contacts are open and Normally Closed (**Err NC**) Auxiliary Contacts are short-circuit.

Maintenance

Switch off the device and release from connections. Clean the trunk of device with a swab. Don't use any conductor or chemical might damage the device. Make sure device works after cleaning.

Warnings

Please use the device according to the manual. Don't use the device in wet. Include a switch and circuit breaker in the assembly. Put the switch and circuit breaker nearby the device, operator can reach easily. Mark the switch and circuit breaker as releasing connection for device.

Technical Specifications

- Operating Voltage(Un) : 120V - 240V AC 50/60Hz.
- Operating Frequency : 50/60 Hz.
- Operating Power : <10VA
- Operating Temp. : -20°C.....+55°C
- Display : 3x3 dijit display, 2x LED
- H.Current (Overload) : 25A - 50A (KON-TER-50)
- Waiting time (t) : 1sec. - 20sec.
- Asymmetry - Delay : %50(Fixed) - 2sec. delay
- Max. Voltage (Contact) : 250VAC
- Max. Current : 50A (KON-TER-50)
- (Resistive Load)(Contact)
- Mech. Endurance(Contact) : 100.000 times
- Elect. Endurance(Contact) : 6.500 times
- Connection Type : Terminal Connection
- Auxiliary Contacts : 3A / 250V AC (Resistive Load)
- Cable Diameter : 2.5mm² (Supply, Contacts)
Max.: 95mm² (Current Input & Outputs)
- Weight : Max. 700gr.
- Mounting : Assembled on the din rail.
- Operating Altitude : <2000m.

KON-TER-XX Connection Diagram (Three-phase)

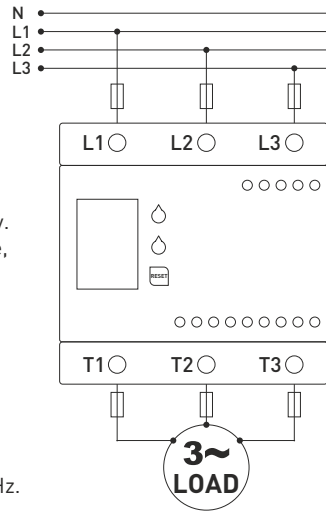

KON-TER-XX Connection Diagram (Mono-phase)

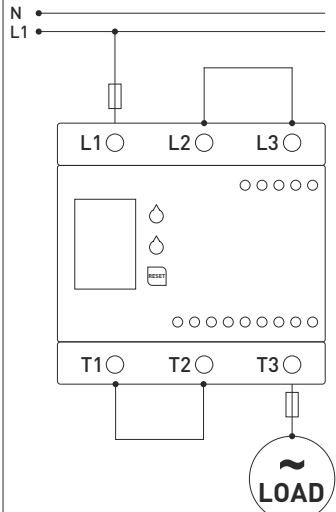

KON-TER-XX Star-Delta Connection Diagram

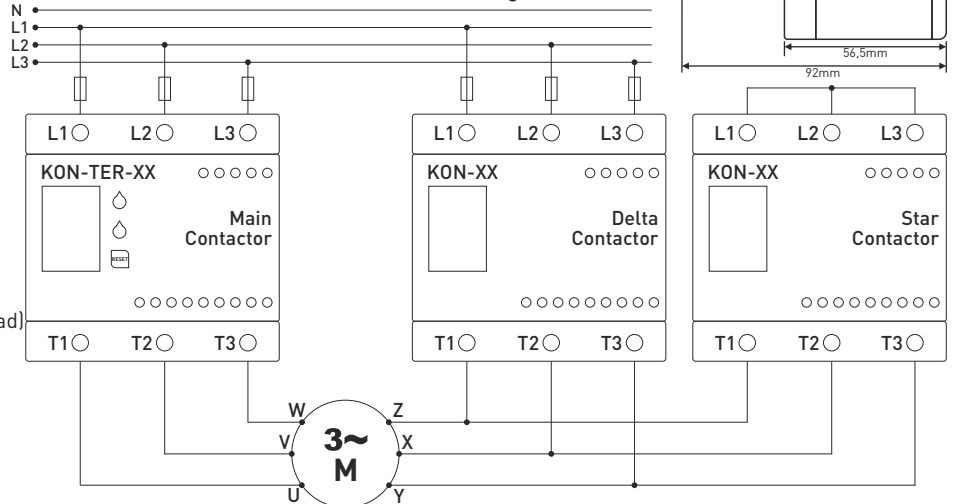

Dimensions

